



PCI and PCI-X Placement Rules for IBM System i5, @Server i5, and iSeries servers with i5/OS V5R4 and V5R3

Note to the reader: System i is a term that describes the combination of System i5, @server i5, @server iSeries™, and AS/400 product lines. IBM® System i5 is the follow-on product line to the @server i5 and iSeries systems.

In this Redpaper, System i5 refers specifically to the 1.9 GHz Models 520, 550, and 595, and the 2.2 GHz Model 570 announced in January 2006.

In this Redpaper, @server i5 refers specifically to the 1.5 and 1.65 GHz Model 520, and the 1.65 GHz Models 550, 570, and 595 announced in 2005 and 2004.

This IBM Redpaper describes the configuration and card placement rules that you must understand and follow to develop valid configurations with i5/OS® V5R4, V5R3, and with V5R3M5 licensed machine code (LIC) for the following servers:

- ▶ IBM System i5 Models 520, 550, 570, 595
- ▶ IBM @server i5 Models 520, 550, 570, 595
- ▶ IBM @server iSeries Models 800, 810, 820, 825, 830, 840, 870, 890

Use it as a guide when configuring IOAs and IOPs so that the system is sized to meet customer expectations.

Refer to *PCI Card Placement Rules for the IBM @server iSeries Server Version 5 Release 2*, REDP-3638 for the following information:

- ▶ For rules related to the iSeries Models 270, 820, 830, 840, SB2, and SB3 configurations with OS/400® V5R2
- ▶ For rules related to the iSeries Models 800, 810, 825, 870, and 890 configurations with OS/400 V5R2

For rules related to #5033, #5034, #5035, and #5077 Migration Towers that can attach to Models 820, 830, 840, SB2, or SB3, and the description of the affected features to be

migrated, see Chapter 5, “iSeries tower schematics,” and Chapter 6, “iSeries 800, 810, 820, 825, 830, 840, 870, and 890 model features,” of the October 2005 edition of the *IBM @server i5, iSeries, and AS/400e System Builder*, SG24-2155, available at:

<http://www.redbooks.ibm.com/redbooks/pdfs/sg242155.pdf>

or the iSeries Information Center on the Web at:

<http://publib.boulder.ibm.com/pubs/html/as400/infocenter.htm>

In addition, for performance-related information about System i configurations, review the *iSeries Performance Capabilities Reference*, on the Web at:

<http://www.ibm.com/servers/eserver/series/perfmgmt/resource.htm>

PCI technology

The implementation of Peripheral Component Interconnect (PCI) architecture provides flexibility in the placement of input/output processors (IOPs) and input/output adapters (IOAs) in IBM System i models. PCI architecture changes the configuration rules associated with card placement.

The industry standard PCI technology was introduced to the AS/400® product line in August of 1997. Earlier models required IOPs to be in specific slots in the system and expansion towers. A second generation of PCI was introduced starting with iSeries Models 825, 870, and 890 in February 2003. This is known as PCI extended (PCI-X) architecture. A third generation of PCI is now offered with the introduction of the 1.9 GHz System i5 Model 520 processor in February 2006. This model has a PCI-X slot that runs at a maximum of 266 MHz and supports only adapters that can run without an IOP. This slot is ideally suited for ultra high bandwidth adapters like the new 266 MHz (DDR) SCSI adapters.

Note: The 266 MHz rating is referred to as “double data rate” (DDR) because the previous maximum speed was 133 MHz.

With the introduction of the “dual mode” I/O adapters (IOAs) for i5/OS in February 2006, the System i5 and @server i5 models now have three types of i5/OS adapters:

- ▶ IOP controlled IOAs
- ▶ IOP-less only IOAs
- ▶ Dual mode IOAs

Dual mode capability is based on the i5/OS level. Dual mode adapters are capable of running with or without an IOP. If the dual mode IOA is placed in a slot that is under IOP control, then the IOA runs as IOP-based. If the slot is not controlled by an IOP, then the adapter runs in IOP-less mode.

IOP control of a dual mode adapter always takes precedence over IOP-less, except in specific load source situations, as described in “IPL Load Source (LS) rules” on page 13. Note that an IOP in one partition cannot control an IOA in a different partition. The system and tower diagrams in this Redpaper illustrate if a slot is under IOP control.

To make it easier for users, dual mode IOAs are assigned separate feature codes based on whether the IOA is to be used as IOP-controlled or as IOP-less. It is the same physical adapter. The IBM marketing configurator uses the customer feature selection to determine if an IOP is needed with the IOA purchased.

Increased configuration flexibility reinforces a requirement to understand detailed configuration rules.

Important: If the configuration rules and restrictions are not fully understood and followed, it is possible to create a hardware configuration that does not work, marginally works, or quits working when a system is upgraded to future software releases.

Consider the following guidelines when placing PCI and PCI-X adapters:

- ▶ PCI-X adapters are backwards compatible with the PCI slots. This means that any PCI-X adapter functions in a PCI slot.
- ▶ Unless otherwise noted, place a PCI-X adapter in a PCI-X slot for best performance.
- ▶ Adapters have 64-bit or 32-bit connectors. 64-bit connectors are backwards compatible with 32-bit slots.
- ▶ #5074/#5079 towers have some *5 volt only* slots. An adapter card must be 5-volt compatible to go in slots C06, C07, C12, and C13. Many of the newer adapters are not capable of 5-volt operation. Adapter cards are notched so that the card does not plug into the slot if the slot voltage and card voltage are not compatible.
- ▶ For best performance, match the card and slot characteristics by using a 64-bit adapter in a 64-bit slot. Match the slot frequency to the card frequency. Card frequencies are: 33 MHz, 66 Mhz, 133 Mhz, or 266 MHz.
- ▶ i5/OS IOP-less adapters are supported in Model 520, 550, 570 and 595 systems.

PCI-X is backwards compatible and can run at slower speeds. This means you can plug a PCI-X adapter into a PCI slot and it runs at the PCI speed, not the PCI-X speed. This can result in a more efficient use of card slots, which in turn can lower the cost of implementation. For example, a specific PCI IOP can support two high-performance IOAs, or four slower IOAs, but may not have the capacity to support one high-performance IOA and two slower IOAs.

PCI slots and adapters have a maximum speed of 66 MHz. With the new higher speed processor features in the model 520 that run at 1.9 GHz, a PCI-X slot has been added that runs at 266 MHz and is IOP-less capable only.

PCI and card enclosure concepts

Knowledge of such concepts as *Multi-Adapter Bridge*, *Multi-Adapter Bridge Boundaries*, and *Multi-Adapter Bridge Bus Number* is required to understand the card rules defined in this Redpaper.

Note: For the purpose of this Redpaper, the term *Multi-Adapter Bridge bus number* is used to facilitate the explanation of PCI card plugging rules

A Multi-Adapter Bridge defines a logical grouping of card slots in the card enclosure. Each Multi-Adapter Bridge contains eight Multi-Adapter Bridge buses numbered 1 through 8.

The sequence of bus numbers does not always correspond with the sequence of card slots in the card enclosure. For example, as illustrated in the Model 520 diagram in “Card enclosure diagrams: Models 520, 550, 570, and 595” on page 7, the base IOP is in slot C6, Multi-Adapter Bridge 1, bus 1 and 2 (a 64-bit slot). Slot C3 is Multi-Adapter Bridge bus 3 only (a 32-bit slot), slot C05 is Multi-Adapter Bridge bus 7 and 8. Slot C1 is Multi-Adapter Bridge 2, bus 1 and 2, and slot C2 is Multi-Adapter Bridge 2, bus 3 only.

An IOP addresses the IOAs in sequence by the Multi-Adapter Bridge bus number, rather than the slot number. Using the previous example, the Model 520 base IOP controls the IOAs installed in slots C3 and C5 as they belong to the same MAB.

Note: PCI card installation instructions refer to the slot number, rather than the Multi-Adapter Bridge bus number.

All card enclosures, except for Models 800 and 810, contain more than one Multi-Adapter Bridge. The divide between these Multi-Adapter Bridges is called a *Multi-Adapter Bridge Boundary* (MABB). An IOP can control a maximum of four IOAs installed in higher number Multi-Adapter Bridge buses, up to another IOP or a MABB.

Models 520, 550, 570 with processors less than 1.9 GHz must have an IOP installed in the Multi-Adapter Bridge. Some System i5 models are shipped with a base #984x IOP feature code. Models 800 and 810, and the #5075 PCI Expansion Tower have an IOP embedded on the backplane of the card enclosure that occupies Multi-Adapter Bridge bus 1 of the first, or only, Multi-Adapter Bridge.

In the diagrams represented in the *Card enclosure diagrams for System i5 eServer i5, and iSeries servers and towers* section starting on page 6, any card slots that have a single Multi-Adapter Bridge bus number are 32-bit slots. Card slots that have dual Multi-Adapter Bridge bus numbers are 64-bit slots. Models 800 and 810 support 32-bit slots only.

Note: PCI cards and card enclosure slots are either “short” or “long”. See the “Card type” column and the first footnote for Table 3 in “Hard rules: System i5, eServer i5, and iSeries IOA capabilities” on page 14 for information about which cards are “long” cards and cannot be installed in the “short” position.

Integrated xSeries® (IXS) or Netfinity® Servers occupy one-and-a-half slots, two slots, or two-and-a-half slots, depending on the system and Integrated Server.

One slot in each Model 800, 810, 825, 870, and 890 system card enclosure is SCSI, as shown in the system graphics in Figure 4 on page 10 in the Card enclosure diagrams: Models 520, 550, 570, and 595 section. The first, or only, disk unit controller is installed in this slot and supports the load source disk unit, base internal tape (if installed), and base CD-ROM/DVD-RAM. The SCSI card slot is controlled by the embedded or base IOP in a system card enclosure.

Models 520, 550, 570 with processors less than 1.9 GHz have embedded SCSI controllers that are controlled by the base IOP. The 520, 550, and 570 models with 1.9 GHz processors and above have embedded SCSI controllers that are IOP-less capable.

Follow these rules for disk controller placement:

- ▶ Models 800 and 810 can, in certain cases, support a second disk unit controller when the #7104 System Unit Expansion or #7116 System Unit Expansion is installed. The load source disk controller must be in slot C01.
- ▶ For the #5075 PCI Expansion Tower, the disk unit controller must be in slot C01.
- ▶ For the #5074/#5079 PCI Expansion Tower, the disk controller can be placed in slot C02, C03, or C04.
- ▶ For the #0694/#5094/#5294 1.8m I/O Tower, the first disk unit controller must be in slot C02 through C09.

- ▶ Two disk unit controllers are allowed in the #0595/#5095 PCI-X Expansion Tower and can be in any IOA slot.
- ▶ In the #9194 Base PCI-X Expansion Tower of the Model 595, the first disk controller must be in slot C03.
- ▶ A Model 520 allows one additional disk unit controller if a #6594 4-Disk Slot Expansion PCI-X Controller is installed.
- ▶ A #6594 allows the second four-pack DASD bay to be controlled by the additional disk unit controller SCSI.

Configuration rules for System i5 and eServer i5 Models 520, 550, 570, 595, and iSeries Models 800, 810, 825, 870, and 890

This section provides the basis to understand placement and configuration rules as they apply to System i5 and eServer i5 Model 520, 550, 570, and 595, and iSeries Models 800, 810, 825, 870, and 890 configurations.

“Hard”, “soft”, IXS and Linux® rules define the combinations of IOPs and IOAs supported in servers described in this section:

- ▶ **Hard rules:** Rules and restrictions that are checked and enforced by the IBM Marketing Configurator. The hard rules for these models are documented in “Hard rules: System i5, eServer i5, and iSeries IOA capabilities” on page 14, as well as with the individual feature descriptions in the January 2006 edition of the *IBM System i5, @server i5, and iSeries System Builder*, SG24-2155.

For non-partitioned systems we recommend that, when you upgrade a system, you send a Work with Order Information (WRKORDINF) request. This command sends information that is unique to the system configuration, to the IBM administrative system to validate orders.

To initiate this process, enter a WRKORDINF request. Then to validate the upgrade, register on the Web at:

<http://www.as400service.ibm.com>

You can access the Physical Device Placement Assistant on the Web at:

<http://www-912.ibm.com/supporthome.nsf/document/29084424>

If the URL listed above forces you to a sign-on with an authorization panel, please use this URL:

<http://www-1.ibm.com/servers/eserver/series/news/pdpa.htm>

- ▶ **Soft rules:** Rules and restrictions on combinations of IOAs that are allowed under a single IOP based on how the IOAs are used. They are entirely usage dependent, so the IBM Marketing Configurator cannot enforce them. Soft rules are documented in Table 5 on page 23.

– Communication lines

Soft rules apply to how communication lines are used. Soft rules must be followed when using the #4745 PCI 2-line WAN IOA, #9771 Base PCI Two-Line WAN with integrated modem, #2742 Two-Line WAN IOA, or #2793/#2794 #9793/#9794 PCI Dual WAN/Modem IOA in any of the following situations:

- **High-speed lines:** Running synchronous PPP, SDLC, Frame Relay, or X.25 when the line speed is greater than 64 Kbps
- **X.25:** When more than 64 virtual circuits are required per IOA

- **Frame Relay:** To use frame relay
- **SDLC:** If more than 64 controllers are to be attached per line
- **IPX™:** If IPX protocol is to be used (OS/400 V5R1 and earlier)

In addition, the soft rules may apply in the following situations:

- **LAN:** For best performance using the #2743, #2744, #2760, #2849, #4838, #5700, or #5701 high-speed LAN IOAs
- **IPX:** When running IPX on LAN (OS/400 V5R1 and earlier)
- **ATM:** For best performance or to run multiple emulated LANs on a #2817, #4815, #4816, or #4818 ATM IOA, or to run more than 1024 NWI switched virtual circuits on the #2817 PCI 155 Mbps MMF ATM IOA.

Note: OS/400 V5R2 is the last release to support ATM IOAs.

- ▶ **Integrated xSeries or Integrated Netfinity Servers:** Have a unique set of rules that are separate and distinct from the rules for other IOPs and IOAs. These rules are automatically enforced by the IBM Marketing Configurator. They are described in “IOP rules: iSeries Integrated Server” on page 26.
- ▶ **Linux Direct Attach:** There are distinct card placement rules for Linux partitions. See the January 2006 or October 2005 edition of the “*System Builder*” (*IBM System i5, @server i5, and iSeries System Builder*, SG24-2155, and *IBM @server i5, iSeries, and AS/400e System Builder*, SG24-2155 respectively).

Card enclosure diagrams for System i5 eServer i5, and iSeries servers and towers

This section describes the layout of the card enclosures for the IBM System i5 and @server i5 Models 520, 550, 570, 595, and iSeries 800, 810, 825, 870, 890 servers, and supported PCI expansion towers.

Note: Card enclosure layouts for iSeries 270, 820, 830, 840, SB2, and SB3 servers are described in *PCI Card Placement Rules for the IBM @server iSeries Server Version 5 Release 2*, REDP-3638.

The discussions in this section refer to card enclosure diagrams on pages 7 - 11. These diagrams illustrate PCI slot locations and the numbering on the backplanes of the servers and the PCI expansion towers represented in this Redpaper for cards controlled by i5/OS, OS/400, and Linux.

Mixing cards controlled by i5/OS with those controlled by a non-i5/OS operating system is allowed within the same MABB. Mixing is not allowed in the first MABB in Models 825, 870, and 890. Limited mixing is allowed in Models 800 and 810.

Card enclosure diagrams: Models 520, 550, 570, and 595

Figure 1 shows PCI slot locations and numbering on the system unit backplanes of the Models 520, 550, 570, and 595 as supported by i5/OS and Linux.

Figure 1 PCI slot locations and numbering of Models 520, 550, 570, and 595

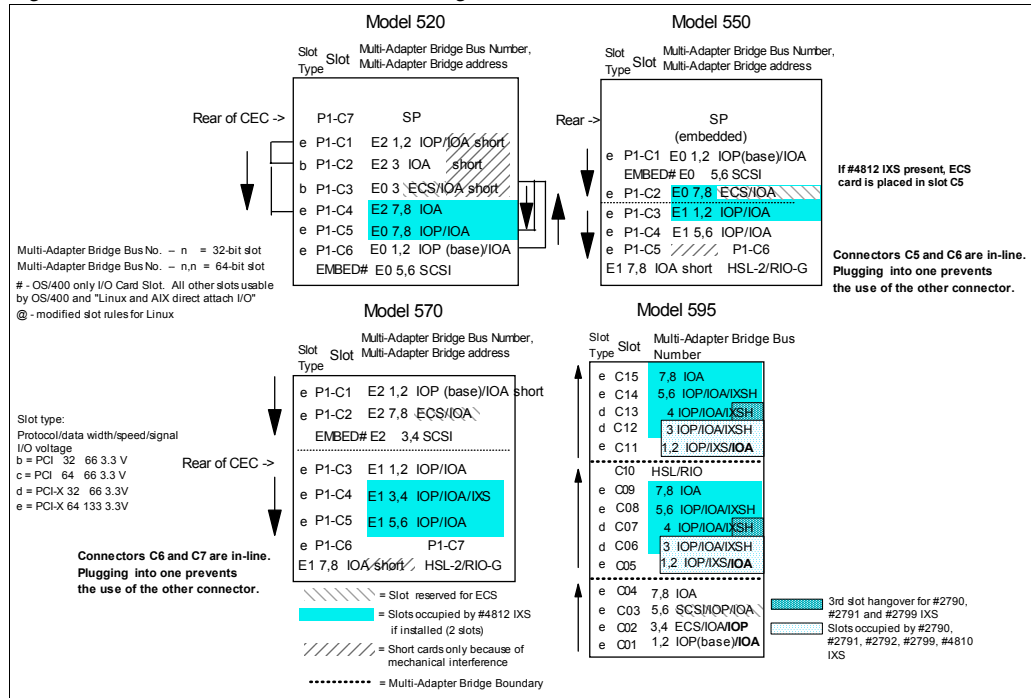

For the model 520, the planar layout shown in Figure 1 is capable of supporting dual mode adapters with i5/OS V5R4. Dual mode adapters are adapters that can be either IOP-less or IOP controlled. If an IOP is placed on the same Multi-Adapter Bridge number and at a lower address number, then dual mode adapters are under IOP control and do not function as an IOP-less adapter. The embedded SCSI on the model 520 with the 1.5 GHz and 1.65 GHz processor is only supported with an IOP using i5/OS V5R3 or later.

For the model 570, the embedded SCSI is Multi-Adapter Bridge number E2 and address 3,4. If a #5728 or #5726 is installed, then all six disk unit slots are controlled by address 3,4. Without these features then address 3,4 controls only three DASD bays. The other three DASD bays are controlled by Multi-Adapter Bridge number E0, address 1 (IOP-less only).

Figure 2 shows PCI slot locations and numbering on the POWER5+™ 1.9 GHz processor Model 520 systems.

Figure 2 PCI slot locations and numbering of Model 520 with 1.9 GHz processor

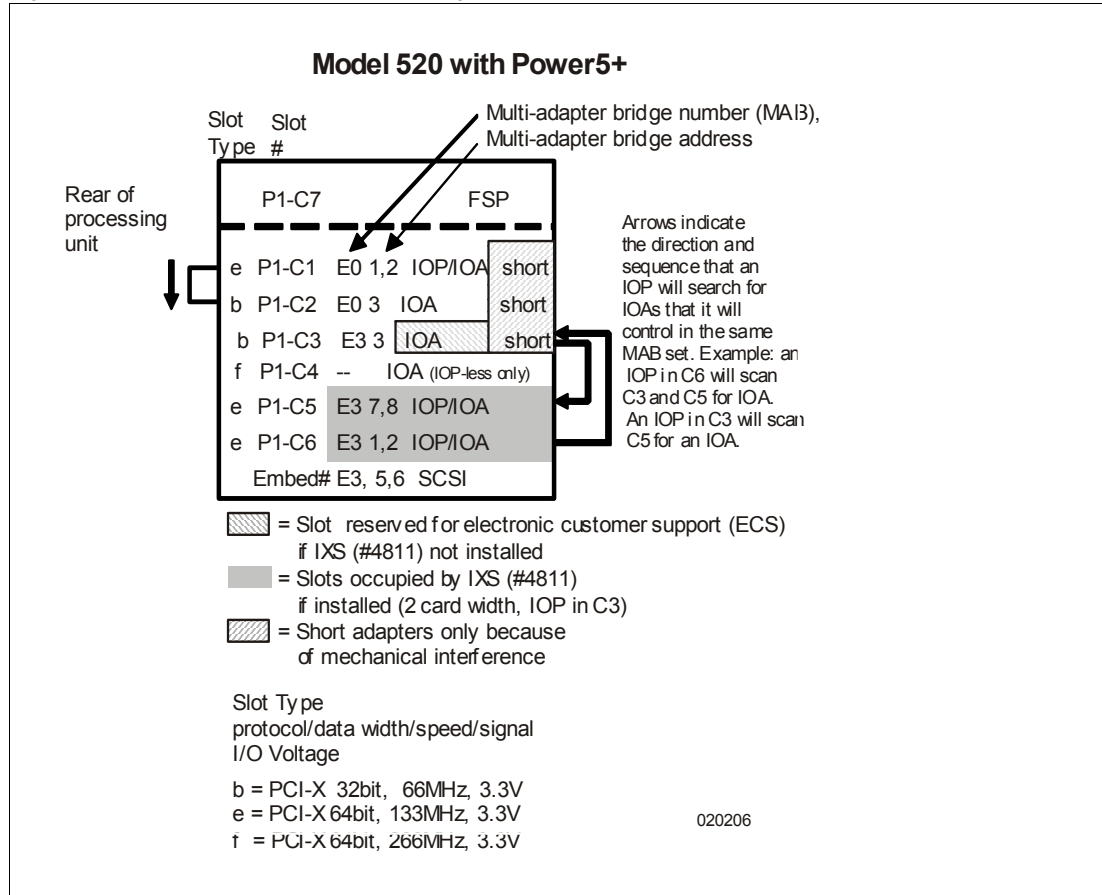

The planar layout shown in Figure 2 is capable of supporting dual mode adapters at i5/OS V5R3 and V5R3M5 LIC.

If an IOP is placed on the same Multi-Adapter Bridge number and at a lower address number, then this adapter is under IOP control and does not function as an IOP-less adapter. This rule also applies to the embedded SCSI controller. For example, if an IOP is placed in slot C6, then the embedded SCSI controller is under IOP control since the embedded SCSI controller is at Multi-Adapter Bridge number E3 and Multi-Adapter Bridge address 5, 6 (not shown in the diagram). The IOP is at Multi-Adapter Bridge number E3 and Multi-Adapter Bridge address 1,2. Since the address of the IOP is lower on the embedded SCSI controller, the IOP controls it.

Card enclosure diagram: #5790 PCI Expansion Drawer

Figure 3 shows PCI slot locations and numbering on the backplane of the #5790 PCI Expansion Drawer, as supported by i5/OS and Linux.

#5790

Slot Type	Slot	Multi-Adapter Bridge Number, Multi-Adapter Bridge address
e	P1-C7	E2 7,8 IOA
e	P1-C6	E2 3,4 IOP/IOA/IXS
e	P1-C5	E2 1,2 IOP/IOA

e	P1-C3	E1 7,8 IOA
e	P1-C2	E1 3,4 IOP/ IOA/IXS
e	P1-C1	E1 1,2 IOP/IOA

 = Slots occupied by #4813 if installed (2 slots)

Figure 3 PCI slot locations and numbering of #5790 PCI Expansion Drawer

Card enclosure diagram: Models 800, 810, 825, 870, and 890

Figure 4 shows PCI slot locations and numbering on the backplanes of the Models 800, 810, 825, 870, and 890 as supported by i5/OS. It also shows the #5088/#0588, #5095/#0595, and #9094 PCI-X Expansion Towers.

Note: The #4811, #4812, #4813, #9812, and #9813 Integrated xSeries Servers consist of an Input Output Adapter only, and therefore require an IOP.

The earlier Integrated xSeries Servers (PCI Integrated Netfinity Server and PCI Integrated xSeries Server features #2790/#2890, #2791/#2891, #2792/#2892, #2799/#2899, and #4710/#4810) have an IOP as part of the IXS adapter.

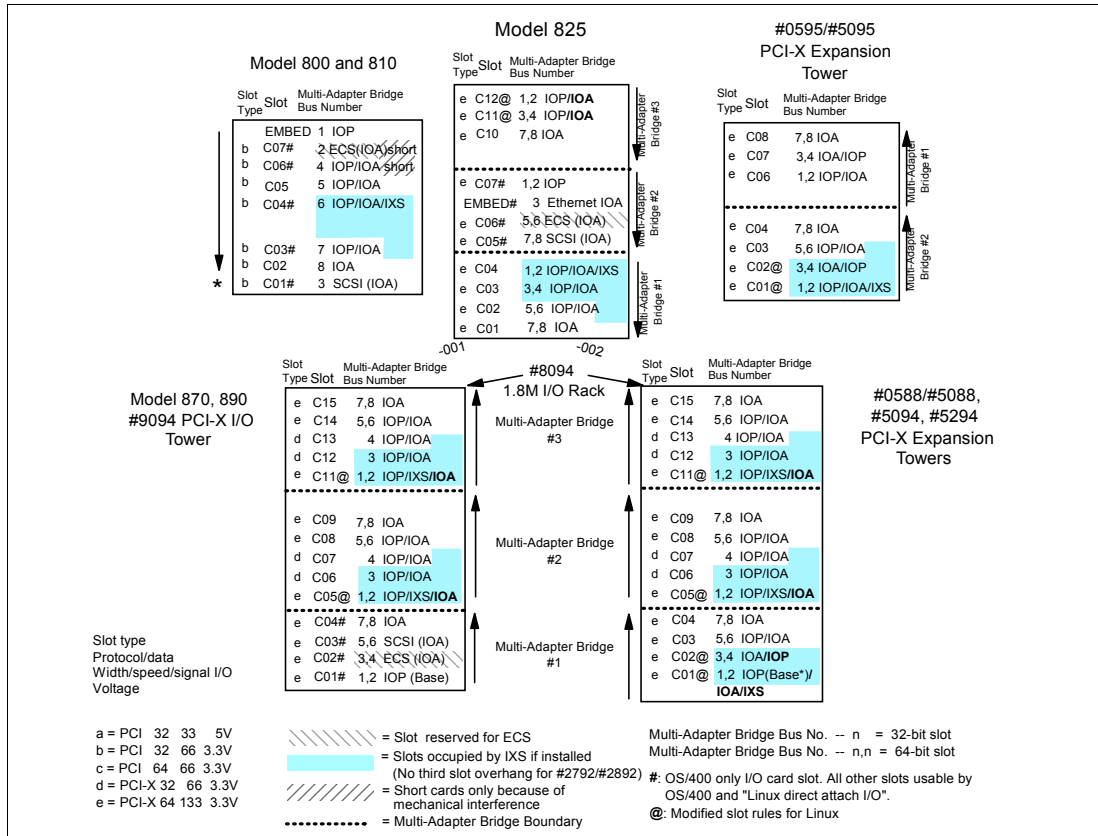

Figure 4 PCI slot locations and numbering of Models 800, 810, 825, 870, and 890

Note: A #2890, #2891, #2899, #2892, and #4810 Integrated xSeries Server do function if placed in slots C01 and C02 of the #5094/#5294/#8094. However, initial placement in slots C01 and C02 is not supported from the plant nor by the IBM Marketing Configurator.

Because of mechanical limitations, the only Integrated xSeries Server that slots C01 and C02 of the #5088/#5088 can accommodate is the #2792/#2892 and #4810 Integrated xSeries Server.

Card enclosure diagram: #5074 PCI Expansion Tower

Figure 5 shows PCI slot locations and numbering on the backplanes of the #5074 PCI Expansion Tower. Note that the #5074 tower has 5.0 V slots that are not compatible with any adapters which are 3.3 V only.

Note: The #5074 diagram is rotated 90 degrees counter-clockwise from the actual horizontal position for illustration purposes.

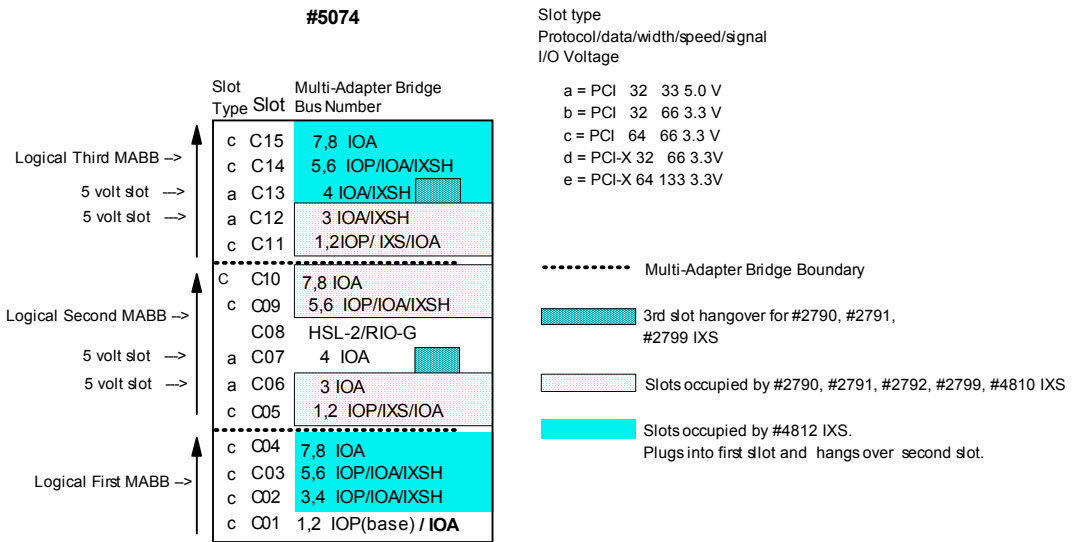

Figure 5 PCI slot locations and numbering of #5074 PCI Expansion Tower

Configuration validation procedure for System i5 IOPs

Each IOP and IOA available for the IBM System i5 and @server i5 Models 520, 550, 570, 595, and iSeries Models 800, 810, 825, 870, 890 have a set capacity. The utilization of the IOP is affected by the line speed, number of lines, protocol, and various other factors of the IOAs it controls.

Note: To define a configuration for an IOP to service multiple IOAs, take into account the demand placed on the IOP by the IOA so that you can generate a valid configuration.

The IBM Marketing Configurator generates valid configurations that follow all the hard rules. When the soft rules must be used due to line speed or protocol, the procedure defined in this section allows for validation of the proposed customer configurations that are created using the marketing configurator. This allows the configuration to be adjusted to make allowances for the soft rules prior to placing an order.

This section describes a simple method to determine whether the IOAs selected, and their usage, overburden a specific IOP.

Generating a valid configuration

To determine whether a specific IOP is capable of supporting the IOAs considered for attachment, follow this procedure to complete Table 1 in the Configuration validation form on page 12:

1. Identify the IOP being considered.
2. Determine the capacity values for the selected IOP using Table 2 in the IOP capacity table. on page 12. Enter the values in the Configuration validation form. See Table 1.
3. Identify the IOAs to be controlled by the selected IOP.
4. Determine the capacity requirements of the selected IOAs using the storage (memory) and performance values from Table 3 on page 14. Enter the values onto lines 1 through 4

of the “Configuration validation form” on page 12 (Table 1). Enter one IOA per line. Remember that one IOP supports a maximum of four IOAs.

5. Review Table 5 on page 23, which shows the soft rules for IOA requirements. If any of the restrictions that are described apply to the selected IOAs, use the values from Table 5 to replace the values in the Configuration Validation Form, unless the value in a particular column is less than the default value for the IOA. When determining the values to use, be sure to account for both lines if you select the #2742 Two-Line WAN IOA, #2793/#2794 Two-Line WAN IOA with Modem, #4745 PCI 2-line WAN IOA, #9771 Base PCI Two-Line WAN with integrated modem, or #9793/#9794 Base PCI Two-Line WAN with integrated modem.
6. Add the IOA values in each column of Table 1. Place the total on line 5.
7. Compare the totals on line 5 of Table 1 with the IOP Capability value on line 6.

If the number on line 5 is greater than the corresponding value on line 6, the selected IOAs exceed the capacity of the selected IOP. Add one or more IOPs to the configuration to support the selected IOAs.

If all the numbers on line 5 are less than, or equal to the corresponding values in line 6, the configuration is valid as long as all card rules are followed, as described in Hard rules: System i5, eServer i5, and iSeries IOA capabilities on page 14, and “Soft rules: System i5, eServer i5, and iSeries IOA requirements” on page 23. See Table 5 on page 23.

Configuration validation form

Use Table 1 as a worksheet when following the procedure from the previous section.

Table 1 Configuration validation form

Line	Item	Memory	Performance
1	IOA #1		
2	IOA #2		
3	IOA #3		
4	IOA #4		
5	Total		
6	IOP Capability		

IOP capacity table

Table 2 identifies the memory and performance capacity characteristics of select IOPs.

Table 2 IOP capacity

IOP feature number	Server or tower	Memory capacity	Performance capacity
#2843/#9943/#2844/ #9844 PCI IOP	Model 800, 810, 825, 870, 890, #5074/#0574, #5094/#0694, #5095/#0595, #5088/#0588, #5078/#0578, #5294, #8079, #8093, #8094, #9074, #9094	211	100
Embedded IOP Embedded IOP Embedded IOP	Model 800 CCIN 286C Model 810 CCINs 284E, 286D, 286E #5075 PCI Expansion Tower CCIN 284B	100	100

IOP rules

The rules for maximizing the IOPs are as follows:

- ▶ A #2847 is a dedicated IOP for Fibre Channel. Only one #2787 or #5760 is allowed with #2847 IOP and no other IOAs. This includes any embedded IOAs. Hardware Management Console (HMC) is required.

The IOP cannot be placed where embedded adapters require an IOP. Do not place this IOP in the following system slots:

- Slots C6, C5, or C3 in a Model 520
 - Slots C1 and C2 in a Model 550
 - Slots C1 and C2 in a Model 570
- ▶ A maximum of four IOAs are allowed on any IOP
 - ▶ Limit the number of features per unit. Such limitations include maximums of:
 - Two IOP features in the Model 800 and 810 system unit
 - Three IOP features in the #5075 PCI Expansion Tower or #5095 PCI-X Expansion Tower
 - Four IOP features in the Model 825, 870, or 890 system unit
 - Five IOP features in the #5074 PCI Expansion Tower
 - Six IOP features in the #0578/#5078 PCI Expansion Unit
 - Four #2843, #2844 PCI IOP features (and one #9844 Base PCI IOP) in the Model 870, 890, and 595 system unit (#9094 Base PCI I/O Enclosure)
 - Five #2843, #2844 PCI IOP features (and one #9844 Base PCI IOP) in the #5094 PCI-X Expansion Tower
 - Six #2843, #2844 PCI IOP features in the #0588/#5088 PCI-X Expansion Unit
 - Two PCI IOPs in Models 520 and 550
 - ▶ IOPs cannot be placed in consecutive slots. The #2843/#2844 can be placed in a slot following the #2792/#2892 or #4710/#4810 IXS adapters.
 - ▶ The #2844/#9844 Base PCI IOP must not be placed in a 5-volt slot.

IPL Load Source (LS) rules

Load source placement rules differ depending on whether a load source is found on an IOP or not, as follows:

If the load source is specified:

1. A IPL is attempted on that resource.
2. An IOP IPL of the system is attempted.
3. When the load source specified is an IOA:
 - a. An IOP-less IPL is attempted.
 - b. If an IPL fails, a “Search for LS” is started (see next item).

If a load source is not specified or found:

1. A search is done.
2. If the load source is under an IOP, then:
 - a. All valid IOA and device combinations under the IOP are attempted.

3. When the load source is an IOA not under IOP control, then:
 - a. An IOP-less IPL is attempted.
4. When the load source is an IOA and there is an IOP capable of controlling it, then:
 - a. All devices under the IOA are searched in a sequence of IOP followed by IOP-less.
(For example, device 1 IOP, device 1 IOP-less, device 2 IOP, device 2 IOP-less, etc. ...)

Hard rules: System i5, eServer i5, and iSeries IOA capabilities

This section identifies the hard rules that are associated with the capability of each PCI IOA.

Models 520, 550, and 570 have integrated SCSI controller and must be included in IOP calculations. See the end of Table 3 for values.

Table 3 Hard rules for IOA capabilities

IOA	Card type ¹	Storage	Performance
#2742 Two-Line WAN IOA	C	15	14
#2743 1 Gbps PCI Ethernet IOA ²	H	2	26
#2744 PCI 100 Mbps Token Ring IOA ^{3,14}	A	25	36
#2749 PCI Ultra Magnetic Media Controller ¹⁰	A	22	25
#2757 PCI-X Ultra RAID Disk Controller ^{5, 8, 11, 12, 26}	G	29	30
#2760 PCI 1 Gbps Ethernet UTP Adapter ²	H	2	26
#2763 PCI RAID Disk Unit Controller ^{5, 8, 11, 13}	B	29	21
#2765 PCI Fibre Channel Tape Controller ⁹	E	36	50
#2766 PCI Fibre Channel Disk Controller ⁹	E	Note 9	Note 9
#2768 PCI Magnetic Media Controller ¹⁰	A	22	25
#2772/#2773 PCI Dual WAN/Modem IOA ¹⁸	A	15	14
#2780 PCI-X Ultra4 RAID Disk Controller ^{5, 8, 11, 12, 26}	G	29	30
#2782 PCI-X RAID Disk Unit Controller ^{5, 8, 11}	G	29	21
#2787 PCI-X Fibre Channel Disk Controller ⁹	I	Note 9	Note 9
#2793/#2794/#9793/#9794 PCI Dual WAN/Modem IOA ¹⁹	C	15	14
#2805/#2806 PCI Quad Modem ¹⁹	D	15	14
#2817 PCI 155 Mbps MMF ATM IOA ^{3, 4, 8, 20}	E	35	47
#2849/#9749 10/100 Mbps Ethernet Adapter ³	A	25	36
#4723 PCI 10 Mbps Ethernet Adapter	A	25	12
#4745 PCI 2-line WAN IOA	A	15	14
#4746 PCI Twinaxial IOA ^{14, 15}	A	10	6
#4748/#9748 Base PCI RAID Disk Unit Controller ^{5, 8, 11, 12}	B	29	21
#4778/#9778 Base PCI RAID Disk Unit Controller ^{5, 8, 11, 12}	B	29	25

IOA	Card type ¹	Storage	Performance
#4750/#4751 PCI ISDN BRI S/T IOA ^{7, 16}	B	25	7
#4761 PCI Integrated Analog Modem ^{7, 17}	B	22	7
#4801 PCI Cryptographic Coprocessor ⁶	A	11	18
#4805 PCI Cryptographic Accelerator ⁶	A	2	26
#4806 PCI-X Crypto Coprocessor ⁶	F	IOP-less only	IOP-less only
#4811/#4812/#4813/#9812/#9813 PCI Integrated xSeries Server (IXS)	J	25	51
#4815/#4816/#4818 PCI 155 Mbps ATM IOA ^{3, 4, 8}	A	35	47
#4838 PCI 100/10 Mbps Ethernet IOA ^{3, 14}	A	25	36
#5700 PCI 1 Gbps Ethernet IOA ²²	I	2	26
#5701 PCI 1 Gbps Ethernet UTP IOA ²²	I	2	26
#5702 PCI-X Ultra Tape Controller ²¹	F	29	21
#5703 PCI-X RAID Disk Unit Controller ^{5, 8, 11}	G	29	21
#5704 PCI-X Fibre Channel Tape Controller ⁹	I	36	50
#5705 PCI-X Tape/DASD Controller ²¹	F	29	21
#5706/#5707 PCI-X 1 Gbps Ethernet-SX IOA ²³	F	IOP-less only	IOP-less only
#5709 RAID Enabler Card ²⁴	N/A	29	21
#5712 PCI-X Tape/DASD Controller ²¹	F	29	21
#5715 PCI-X Tape/DASD Controller ²¹	F	29	21
#5726/#9509 RAID Enabler ²⁴	N/A	29	21
#5727 Integrated Cache - 40 MB with RAID ^{24, 30}	N/A	29	21
#5728 Integrated Cache - 40 MB with RAID ^{24, 30}	N/A	IOP-less	IOP-less
#5736 PCI-X Disk/Tape Controller w/IOP ^{21, 30}	K	29	21
#5737 PCI-X Disk Controller 90MB w/IOP ^{5, 8, 11, 30}	L	29	21
#5760 PCI-X Fibre Channel Disk Controller ⁹	K	Note 9	Note 9
#5761 PCI-X Fibre Channel Tape Controller ⁹	K	36	50
#5766 PCI-X Tape Controller ²¹	K	29	21
#5775 PCI-X Tape Controller ^{21, 30}	K	IOP-less	IOP-less
#5776 PCI-X Disk Controller 90MB ^{29,30}	L	IOP-less	IOP-less
#6800 PCI-X 1Gbps Ethernet IOA ²⁹	I	IOP-less	IOP-less
#6801 PCI-X 1Gbps Ethernet UTP IOA ²⁹	I	IOP-less	IOP-less
#6803/#6804#9493/#9494 PCI WAN for ECS ^{28, 30}	C	IOP-less	IOP-less

IOA	Card type ¹	Storage	Performance
#9510 Integrated Cache - 40 MB ^{24, 30}		IOP-less	IOP-less
#9767 Base PCI Disk Unit Controller (CCIN 2767) ¹¹	A	29	21
#9771 Base PCI Two-Line WAN with integrated modem ¹⁴	A	15	14
CCIN 288E Embedded 100/10 Mbps Ethernet IOA (Model 825 only)	N/A	25	36
CCIN 5708 Auxiliary Write Cache IOA (#5580/#5581 uses CCIN 5708) ^{5, 8, 11, 25, 26}	G	29	1
Model 520, 550, 570 embedded SCSI controller ²⁴	N/A	29	21
Embedded SCSI controller in model 520, 550, 570 with 1.9 GHz or 2.2 GHz processor running i5/OS V5R3 with V5R3M5 LIC, i5/OS V5R3 with V5R3M5 LIC or later on 520, or V5R4M0 or later on 550, 570 ³⁰	N/A	IOP-less	IOP-less

Note: The following numbers refer to the superscript numbers in Table 3.

- Cards must be plugged into slots based on their length and power voltage level as indicated in the *Card type* column. Note that 5-volt slots are limited to 33 Mhz, and any card plugged into a 5-volt slot is limited in performance to 33 Mhz. A 64-bit card placed in a 32-bit slot, or a card with higher Mhz placed in a slot with lower Mhz, can have performance limitations. 266 Mhz cards controlled by an IOP are limited to 133 MHz or below capabilities. Card specifications are as follows:

 - A - PCI, 32-bit, 33 Mhz, Universal voltage, short (*universal* means it works in either 3-volt or 5-volt slots)
 - B - PCI, 32-bit, 33 Mhz, Universal voltage, long
 - C - PCI, 32-bit, 66 Mhz, 3V, short
 - D - PCI, 32-bit, 66 Mhz, 3V, long
 - E - PCI, 64-bit, 66 Mhz, Universal voltage, short
 - F - PCI-X, 64-bit, 133 Mhz, 3V, short
 - G - PCI-X, 64-bit, 133 Mhz, 3V, long
 - H - PCI, 64-bit, 66 Mhz, 3V, short
 - I - PCI-X, 64-bit, 133 MHz, Universal voltage, short
 - J - PCI, 64-bit, 66 MHz, 3V, double wide and long
 - K - PCI-X, 64-bit, 266 Mhz (DDR), 3V, short
 - L - PCI-X, 64-bit, 266 Mhz (DDR), 3V, long
- Follow these plugging rules for the #2743 1 Gbps PCI Ethernet IOA and #2760 PCI 1 Gbps Ethernet UTP Adapter. (See Note 22 for #5700 and #5701.):

 - Should not be placed in a 5-volt PCI slot.
 - Should be placed in a 64-bit slot in the #5074, #5075, #5079, and #8079 PCI Expansion Towers.
 - Must be placed in a 64-bit slot in the Model 825, or in the #0578, #0588, #0595, #5074/#0574, #5075, #5078, #5079, #5088, #5094/#0694, #5095, #5294, #8079, #8094, #8294 and #9094 towers.
 - Place this IOA in a 32-bit slot in Models 800 and 810. There are no 64-bit slots in a Model 800 or 810.
 - A total of only one of either (not both) #2743 or #2760 to one per MABB.

- Can be combined with a maximum of one other IOA on an IOP.
- IPX protocol is not supported.

The preceding rules do not apply when the #2743/#2760 is controlled by a #2790/#2890 PCI Integrated Netfinity Server or by a #2791/#2891, #2792/#2892, or #2799/#2899 PCI Integrated xSeries Server. See “IOP rules: iSeries Integrated Server” on page 26.

3. A maximum of two in any combination of the following IOAs is allowed per IOP:
 - #2744 PCI 100 Mbps Token Ring IOA
 - #2817 PCI 155 Mbps MMF ATM IOA
 - #2849 10/100 Mbps Ethernet Adapter
 - #4805 PCI Cryptographic Accelerator
 - #481x ATM IOA (OS/400 V5R2 is the final release to support ATM System i5 adapters)
 - #4838 PCI 100/10 Mbps Ethernet IOA

Not more than one #2744, #2849, or #4838 is allowed per IOP when the IOP also drives any #2817 or #481x ATM IOA.

4. A maximum of one #2817 or #4815, #4816, #4818 IOA is allowed per IOP. ATM is not supported after OS/400 V5R2.

5. A maximum of three in any combination of the following IOAs is allowed per IOP:

- #5702, #5703, #5712, and #5715
- #2757 PCI-X Ultra RAID Disk Controller
- #2763 PCI RAID Disk Unit Controller
- #2782/#5703 PCI-X RAID Disk Unit Controller
- #4748/#9748 Base PCI RAID Disk Unit Controller
- #4778/#9778 Base PCI RAID Disk Unit Controller
- #5736 PCI-X Disk/Tape Controller w/IOP
- #5737 PCI-X Disk Controller 90MB w/IOP
- #5580 - #2780 Controller with Auxiliary Write Cache with CCIN 5708 Auxiliary Write Cache*
- #5581 - #2757 Controller with Auxiliary Write Cache with CCIN 5708 *

* These feature codes are two adapters and count as two IOAs for this rule. Refer to *Planning for IBM @server i5 Data Protection with Auxiliary Write Cache Solutions*, REDP-4003 for more complete placement rules.

6. The #4801 PCI Cryptographic Coprocessor and #4805 PCI Cryptographic Accelerator cannot be controlled by the load source IOP in the Models 800 and 810 system units or by the load source IOP of Models 825, 870, and 890.

A maximum of two #4805s is allowed per IOP (but restricted to a maximum of one per IOP if this IOP is also driving a #2743, #2760, #5700, or #5701 Gbps Ethernet LAN card).

The #4806 is an IOP-less adapter. For partition maximums and other information, see the iSeries Information Center at:

<http://publib.boulder.ibm.com/infocenter/series/v5r3/index.jsp?topic=/rzajc/rzajcco4758.htm>

7. A maximum of one of the following IOAs is allowed per IOP:

- #4750 PCI ISDN BRI U IOA
- #4751 PCI ISDN BRI S/T IOA
- #4761 PCI Integrated Analog Modem

8. Not more than one #2757, #2763, #2780, #2782, #4748, #4778, #5580, #5581, #5703, #9748, or #9778 disk controller is allowed per IOP when this IOP also drives any #2817, #4815, #4816, or #4818 ATM IOA. A #5580/#5581 is not allowed with an ATM IOA.

9. Follow these plugging rules for the #2765, #2766, #2787, #5704, #5760, and #5761 controllers:

- If these adapters are heavily utilized, it is recommended to have one per MABB.
 - Limit the number of controllers per system unit or tower. Such limitations include maximums of:
 - Two (any combination) per MABB
 - Two (any combination) in the Model 800 or 810 system unit
 - Four (any combination) in the Model 825 system unit
 - Three (any combination) in the #0595/#5095 PCI-X Expansion Tower
 - Four (any combination) per #5075 PCI Expansion Tower
 - Five in the Model 870, or 890 Base PCI I/O enclosure
 - Six (any combination) in the #5074, #0578/#5078, and #0588/#5088 Expansion Units
 - Six (any combination) in the top and bottom enclosures of the #5079 and #5294, and in the top enclosure of an #8079, #8093, or #8094
 - For best performance, place this 64-bit card in a 64-bit slot. It can be plugged into a 32-bit slot.
 - A maximum of 16 Fibre Channel-attached tape devices (media changer or tape drive) is supported on the #2765, #5704, and #5761.
 - The #2765, #5704 and #5761 support the alternate installation function. They do not support alternate IPL.
 - A maximum of one target with up to 32 Logical Units (LUNs or ESS volumes) of disk units is supported per #2787, #2766 and #5760. One LUN is the equivalent of an internal disk unit arm.
 - The #2766, #2787, and #5760 PCI Fibre Channel Disk Controllers require a dedicated IOP. No other IOAs are allowed on an IOP.
10. If an external tape device is to be used as an alternate IPL device, and the #2749 PCI Ultra Magnetic Media Controller or #2768 PCI Magnetic Media Controller is not controlled by the embedded or base IOP on the system, use Dedicated Service Tools (DST) to select the device as an alternate installation device.
11. The maximum internal disk unit controllers per system or tower are:
- **Models 520, 550, 570:** Have an embedded SCSI disk controller. The 520 and 550 can have an additional disk controller if a #6594 4-Disk Slot Expansion PCI-X Controller for the Model 520 or #6593 for the Model 550 is installed. The additional disk controller features are the #5703, #5715, #5736, #5737, #5775, and #5776.
 - **Model 595 (#9194):** The #2757, #2763, #2780, #2782, #4748, #4778, #5580, #5581, #5703, or #5715, #5737, #5736, #5775, and #5776 disk unit controllers are supported. Up to nine disk controllers are allowed with a maximum of three #2757, #2780, #4748, #4778, #5580 or #5581. The first PCI RAID Disk Unit Controller must be in slot C03.
The disk unit controllers on the first SCSI cable group must be installed in the card enclosure slot C03 through C09.
 - **Models 800 and 810:** The system unit supports up to two disk unit controllers for its own disk slots and those in the #7116 System Unit Expansion. A second disk unit controller for the system unit cannot be ordered unless the #7116 sidecar is present or ordered. Any combination of two disk unit controllers is allowed in the system unit, except only one #5705 is allowed.
A #5705 PCI-X Tape/DASD Controller or #5715 PCI-X Tape/DASD Controller as the load source controller, can control up to six disk units. RAID is not supported. A #2757, #2763, #2780, #2782, #5580, #5581, or #5703 as the load source controller, can control either 6 or 12 disk units. This means a second system unit disk unit controller can control either 6 or 12 disk units.

With two #2757, #2763, #2780, #2782, #4748, #4778, #5580, #5581 or #5703 controllers, either controller can control 6 or 12 disk units. The first disk unit controller must be in slot C01 and controls the load source disk unit. The #2757 can control up to 18 disk units.

The supported controllers are the #2757, #2763, #2780, #2782, #4748, #4778, #5580, #5581, #5703, #5705, and #5715.

- **Model 825:** Three disk unit controllers are allowed in the system unit card enclosure. The first disk unit controller must be in slot C05 and controls the load source disk unit. The supported controllers are the #2757, #2763, #2780, #2782, #4748, #4778, #5580, #5581 and #5703.

There are three (five-pack) disk unit cages and two removable media bays in the Model 825 system unit. Each DASD cage requires a separate SCSI connection on the controller. The two removable media bays (taken together) require a separate SCSI connection, for a total of four SCSI connections required to drive all cages and the removable media bays.

- The #2757 PCI-X Ultra RAID Disk Controller and #2780 PCI-X Ultra RAID Disk Controller can accommodate four SCSI connections.
- The #4748/#4778 PCI RAID Disk Unit Controller can accommodate three SCSI connections.
- The #2763/#2782/#5703 PCI RAID Disk Unit Controller can accommodate two SCSI connections.

- **Models 870 and 890 (#9094):** The #2757, #2763, #2780, #2782, #4748, #4778, #5580, #5581, #5703, or #5715 disk unit controllers are supported. Up to nine disk controllers are allowed with a maximum of four #2757, #2780, #4748, #4778, in any combination or three #5580 or #5581 in any combination. The first PCI RAID Disk Unit Controller must be in slot C03.

The disk unit controllers on the first SCSI cable group must be installed in the card enclosure slot C03 through C09.

- **#0574/#5074 PCI Expansion Tower:** The #2757, #2780, #4748, #4778, #5580, or #5581 disk controllers are allowed in the card enclosure. A maximum of three disk controllers in any combination are allowed. The first disk controller must be installed in card enclosure slot C02, C03, or C04.
- **#5075 PCI Expansion Tower:** One #2757, #2763, #2780, #2782, #4748, #4778, #5580, #5581, #5703, #5715 or #9767 controller is allowed. It must be installed in card enclosure slot C01.
- **#0694/#8294/#5094 PCI-X Expansion Tower:** The #2757, #2780, #4748, #4778, #5580, #5581, #5703, or #5715 disk unit controllers are supported. Up to nine disk controllers are allowed with a maximum of four (in any combination) of the #2757, #2780, #4748, #4778. Maximum of three #5580 or #5581 in any combination (the #2757, #2780 parts of the #5580/#5581 not to exceed the maximum of four, as stated earlier, regardless of the operating system). The disk unit controllers on the first SCSI cable group must be installed in the card enclosure slot C02 through C09. The IBM Marketing Configurator enforces the four #2757/#2780/#4748/#4778/#5580/#5581 rule and allows up to six lesser IOAs, such as the #5703, in the #5094 tower.
- **#0595/#5095 PCI-X Expansion Tower:** Two #2757, #2763, #2780 #2782, #4748, #4778, #5580, #5581, #5703 or #5715 disk unit controllers are allowed. The disk unit controllers can be plugged into any IOA slot.
- **#5079 1.8 M I/O Tower:** See the #5074 for the limits for the top and bottom unit of the #5079.

- **#5294 1.8m I/O Tower:** See the #0694/#5094 limits for the top and bottom unit of the #5294.
- **#8079 Optional Base 1.8 M I/O Rack:** See #5074 limits for top section.
- **#8093 Optional 1.8 M I/O Rack:** See the #9094 limits for bottom section and #5074 for the top section.
- **#8094 Optional 1.8 M I/O Rack:** See the #9094 limits for lower section and #5094 for the top section.

12. A maximum of 18 disk units is supported by the #4748/#4778 PCI RAID Disk Unit Controller.

Maximum of 20 disk units supported by #2757 and #2780.

Maximum of 15 disk units supported by #5580 and #5581.

Based on hardware configuration, only Models 800 and 810 allow 18 installed disk units. All other models or towers restrict the number of attached disk units to 20 or less. A maximum of two removable media devices (internal tape or CD-ROM/DVD-RAM) are supported.

13. Supported on Models 810, 825, 870, and 890, and #5075 or #5095 only. A maximum of 12 disk units and two removable media devices (internal tape or CD-ROM/DVD-RAM) is supported.

14. A system console must be selected for each Model 800, 810, 825, 870, and 890 system unit. There are four options:

- #5540 System Console on Twinaxial Workstation IOA
- #5544 System Console on Operations Console
- #5546 System Console on 100 Mbps Token Ring
- #5548 System Console on 100 Mbps Ethernet

Note: LAN-attached consoles require a dedicated LAN IOA.

Models 520, 550, 570, and 595 have three additional options:

- #5550 HMC as System Console
- #5553 System Console on 10/100/1000 Mbps embedded Ethernet, (Model 520, port T5, 550 port T9, 570 port T6)
- #5557 System Console on 10/100/1000 Mbps IOP-less Ethernet LAN, port 1 (595 does not have embedded LAN so #5706/#5707 is used)

Note: If the system uses HMC, then the HMC determines the console selection.

The embedded Ethernet and the #5706/#5707 PCI-X 1 Gbps Ethernet-SX IOA adapter is the only IOP-less I/O used for a system console.

For Models 520, 550, 570 the embedded Ethernet is the default console unless #5557 is ordered or the # 5706/#5707 is selected from the “Select Console” screen.

Table 4 defines the placement of the adapters to support the system console function in OS/400 V5R2 and OS/400 V5R1.

Table 4 OS/400 V5R1 and later systems

Model	#5540	#5544	#5546/#5548
800, 810	#9771, #9793/#9794 *** C07	#9771/#9793/#9794 *** C07	#9771, #9793/#9794 *** C07
	#4746 C06, C02		#2744, #4838, #2849 *** C06, C05
520	#4746 C5, C2	#9793/#9794 ** C3	#9771/#9793/#9794 C3 *** #2744 C5, C2 #9771/#9793/#9794 C3 #2849 C5, C2 ***
550	#4746 C4	#9793/#9794 ** C2	#9771/#9793/#9794 C2/C5 *, *** #2744 C4 ** #9771/#9793/#9794 C2/C5 *, *** #2849 C4 **, ***
570	#4746 C4, C6	#9793/#9794 ** C2	#9771/#9793/#9794 C2 *** #4744 C4 or C6 #9771/#9793/#9794 C2 #2849 C4 or C6 ***
595	#4746 C04	#9793/#9794 ** C02	#9771/#9793/#9794 C2 *** #4744 C4 #9771/#9793/#9794 C2 *** #4744 C4
825	#9771, #9793/#9794 *** C06	#9771, #9793/#9794 *** C06	#9771, #9793/#9794 *** C06
	#4746 C03-C01		Embedded LAN (#5548 only) N/A
870 890	#9771, #9793/#9794 **** C02	#9771, #9793/#9794 *** C02	#9771, #9793/#9794 *** C02
	#4746 C04, C06, C07, C08, C09		#2744, #2849 *** C04, C06, C07, C08, C09
* If a #4812 is placed in the system unit, #9771/#9793/#9794 must be placed in slot C5			
** If a #4812 is placed in the system unit, #5546 or #5548 console is not allowed. There is no slot in the system unit for a #2744 or #2849.			
*** The #2849, #9793, and #9794 require OS/400 V5R2			

15. Workstations attached to the #4746 PCI Twinaxial IOA are limited to a maximum of 40 unique device addresses per IOA. The number of active workstation sessions is limited to 120 per IOA.

16. The protocols supported on the #4750 and #4751 remote access ISDN IOAs are:

- PPP
- Fax
- IDLC
- The #4750 and #4751 are not supported after OS/400 V5R1.

17. The protocols supported on the #4761 PCI Integrated Analog Modem are:

- SLIP/PPP (not supported after OS/400 V5R1)
- SDLC (limited to one station per port, and not supported after OS/400 V5R1)
- Fax (not supported after OS/400 V5R2)

18. The #2772/#2773 PCI Dual WAN/Modem IOA has two V.90 ports that support Async, Async-PPP protocol, and Fax. Fax is supported at speeds up to 14.4 Kbps.

19. The #2805/#2806 PCI Quad Modem and #2793/#2794 Two-Line WAN IOA with Modem has one V.92 port that supports Async-PPP protocol and V.34 Fax. Fax is supported at speeds up to 33.6 Kbps.

20. The #2817 PCI 155 Mbps MMF ATM IOA is not allowed in the following slots with OS/400 V5R1, but is allowed in the following slots with OS/400 V5R2:

- C01 of the #5075 PCI Expansion Tower
- C07 or C13 of #5074, #5078, #5079, #9074, #8079 top, and #8079 bottom
- C01 of the #5075 PCI Expansion Tower

Note: ATM is not supported after OS/400 V5R2.

21. This feature is a 64-bit card, but can plug into any 32-bit or 64-bit slot. A 64-bit card can have performance limitations in a 32-bit slot.
22. Follow these plugging rules for the #5700 PCI 1 Gbps Ethernet IOA and #5701 PCI Gbps Ethernet UTP IOA:
- Place in PCI-X slot if available. A 64-bit slot is preferred.
 - Cannot be used for LAN console.
 - “Off load” not supported.
 - Must be placed in a 32-bit slot in the #0578, #5074, #0574, #5075, #5078, #5079, #8079, #8093-002, and #9074 PCI Expansion Towers. Can be placed in a 5-volt slot.
 - Maximum of one #5700 or #5701 per Model 800 and 810

The following rules do not apply when the #5700/#5701 is controlled by a #2790/#2890 PCI Integrated Netfinity Server or by a #2791/#2891, #2792/#2892, #4710/#4810, or #2799/#2899 PCI Integrated xSeries Server. The following rules do apply if controlled by a #2842, #2843, or #2844 IOP.

- Only TCP/IP is supported.
- Limit the quantity of #5700 and #5701 adapters to one per MABB for systems and towers that have more than one Multi-Adapter Bridge.
- The #5700 and #5701 can be combined with a maximum of one other IOA on an IOP.
- IPX protocol is not supported.

See “IOP rules: iSeries Integrated Server” on page 26 for further restrictions when the #5700/#5701 is controlled by PCI Integrated Netfinity or xSeries servers.

23. The #5706 and #5707 are IOP-less adapters. IOP resources are not used when these adapters are used. These adapters do not count in the maximum of four adapters per IOP. These adapters are high performance adapters. A maximum of two per Multi-Bridge Adapter with no other high speed adapters is recommended. For best performance the #5706 or #5707 should be placed in 64 bit, PCI-X slots.
24. On Models 520, 550, 570 there is an embedded SCSI controller that works with a #5709, #5726, #5727, #5728, #9509, and #9510 RAID adapter. Both the embedded SCSI controller and RAID adapter have IOP memory and performance numbers. You only add IOP memory and performance factors once. If the RAID adapter is installed, do not count the embedded SCSI controller IOP memory and performance factors. Count only the RAID adapter numbers.
25. The #5580 and #5581 Auxiliary Write Cache IOAs consist of two adapters. The “Storage” and “Performance” numbers stated here apply to the CCIN 5708 of the write cache IOA. Add the Storage and Performance values for this write cache to the Storage and Performance numbers of the #2757 or #2780.

Refer to the Placement Rules section in *Planning for IBM eServer i5 Data Protection with Auxiliary Write Cache Solutions*, REDP-4003 for more complete placement rules.

26. The #5581 consists of a #2757 PCI-X Ultra RAID Disk Controller and CCIN 5708. The #5580 consists of a #2780 PCI-X Ultra RAID Disk Controller and CCIN 5708.

27. High performance adapter

28. The #6803/#6804/#9493/#9494 PCI WAN for ECS supports ECS function only on the modem port. The RVX port is not supported.

- Starting with i5/OS V5R3 with V5R3M5 LIC on model 520 with 1.9 GHz processor and V5R4M0 for the rest of the 520, 550, 570, and 595 models, this is a dual mode adapter that is capable of functioning IOP-less or IOP controlled. If an IOP is placed on the same Multi-Adapter Bridge number and at a lower address number, then this adapter is under IOP control and does not function as an IOP-less adapter. See feature code #2793 and #2794 for this adapter when used with an IOP.

29. The #6800/#6801 is not supported in the #5074 or #5079 tower.

- A cross-over cable is not supported.
- Starting with V5R4M0 on the 520, 550, 570, and 595 models, this is a dual mode adapter that is capable of functioning IOP-less or IOP controlled. If an IOP is placed on the same Multi-Adapter Bridge number and at a lower address number, then this adapter is under IOP control and does not function as an IOP-less adapter. See feature codes #5700 and #5701 for this adapter when used with an IOP.

30. Starting with i5/OS V5R3 with V5R3M5 LIC on model 520 with 1.9 GHz processor and V5R4M0 on models 550 and 570 with the 1.9 GHz or 2.2 GHz processors, this adapter is capable of dual mode. (This includes the embedded SCSI controller). Dual mode means that it is capable of functioning IOP-less or IOP controlled. If an IOP is placed on the same Multi-Adapter Bridge number and at a lower Multi-Adapter Bridge address number, then this adapter is under IOP control and does not function as an IOP-less adapter.

Soft rules: System i5, eServer i5, and iSeries IOA requirements

Using any information from this soft rule IOA requirements section requires configuration validation. Table 5 identifies the soft rule requirements for System i5, eServer i5, and iSeries IOAs.

Table 5 Soft rules for IOAs

IOA	Capability	Memory (MB) (per port)	Performance factor (per port)
#2742 Two-Line WAN IOA	Async up to 115.2 Kbps	3	7
#4745 PCI 2-line WAN IOA	Async-PPP up to 230.4 Kbps ¹	3	7
#9771 Base PCI Two-Line WAN with integrated modem ⁸	Bisync up to 64 Kbps	1	7
	Synchronous PPP up to 64 Kbps	3	7
#2793/#2794/#9793/#9794 PCI Dual WAN/Modem IOA	Synchronous PPP up to 2048 Kbps ¹	3	11

IOA	Capability	Memory (MB) (per port)	Performance factor (per port)
#2742 Two-Line WAN IOA	SDLC up to 32 stations and line speed up to 64 Kbps	3	7
#4745 PCI 2-line WAN IOA	SDLC up to 64 stations and line speed up to 64 Kbps	4	7
#9771 Base PCI Two-Line WAN with integrated modem ⁸	SDLC up to 254 stations and line speed up to 64 Kbps ¹²	7	7
#2793/#2794/#9793/#9794 PCI Dual WAN/Modem IOA	SDLC up to 32 stations and line speed up to 2048 Kbps ¹	3	13
	SDLC up to 64 stations and line speed up to 2048 Kbps ¹	4	13
	SDLC up to 254 stations and line speed up to 2048 Kbps ^{1, 12}	7	13
#2742 Two-Line WAN IOA	Frame Relay line speed up to 64 Kbps ^{3, 4}	11	7
#4745 PCI 2-line WAN IOA	Frame Relay line speed up to 64 Kbps with IPX ^{3, 4, 5}	17	7
#9771 Base PCI Two-Line WAN with integrated modem ⁸	Frame Relay line speed up to 2048 Kbps ^{1, 3, 4}	11	13
#2793/#2794/#9793/#9794 PCI Dual WAN/Modem IOA	Frame Relay line speed up to 2048 Kbps with IPX ^{1, 3, 4, 5}	17	13
#2742 Two-Line WAN IOA	X.25 up to 32 virtual circuits and line speed up to 64 Kbps ^{2, 3}	8	7
#4745 PCI 2-line WAN IOA	X.25 up to 64 virtual circuits and line speed up to 64 Kbps ^{2, 3}	11	7
#9771 Base PCI Two-Line WAN with integrated modem ⁸	X.25 up to 32 virtual circuits and line speed up to 640 Kbps ^{1, 2, 3}	8	15
#2793/#2794/#9793/#9794 PCI Dual WAN/Modem IOA	X.25 up to 64 virtual circuits and line speed up to 640 Kbps ^{1, 2, 3}	12	15
	X.25 up to 256 virtual circuits and line speed up to 640 Kbps ^{1, 2, 3}	35	15
#2743 1 Gbps PCI Ethernet IOA/#2760 PCI 1 Gbps Ethernet UTP Adapter ^{7, 11, 13}	IPX is not supported ¹⁰	-	-
#2744 PCI 100 Mbps Token Ring IOA ⁷	IPX ⁵	31	72
#2765 PCI Fibre Channel Tape Controller ^{11, 13}	Tape attached	-	-
#4723 PCI 10 Mbps Ethernet Adapter	IPX ⁵	31	24
#4746 PCI Twinaxial IOA ¹¹	Maximum addresses and sessions ⁹	-	-
#4838 PCI 100/10 Mbps Ethernet IOA ⁷	IPX ⁵	31	72
#2817/#4815/#4816/#4818 PCI 155 Mbps ATM IOA ^{7, 10}	Up to two emulated LANs ⁶	89	47

IOA	Capability	Memory (MB) (per port)	Performance factor (per port)
#2817 PCI 155 Mbps MMF ATM IOA ^{7, 10}	1025 up to 2064 NWI switched virtual circuits with one emulated LAN	52	47

Note: The following notes refer to the superscript numbers in Table 5.

1. One high-speed line is allowed per IOP. Consult “Configuration validation procedure for System i5 IOPs” on page 11 to determine if enough memory and performance capacity is available on the IOP to support more than one high-speed line.

The following configurations are defined as high-speed lines:

- Synchronous PPP above 64 Kbps to 2048 Kbps
- SDLC above 64 Kbps to 2048 Kbps
- Frame Relay above 64 Kbps to 2048 Kbps
- X.25 above 64 Kbps to 640 Kbps

Line speeds greater than 64 Kbps have the following restrictions:

- Electrical interfaces X.21, V.35, or EIA-449/V.36 must be used.
- 20-ft. (6-meter) cables must be used for the X.21 and V.35 interfaces.
- “Looped” clocking is required on EIA/449/V.36 cables longer than 20-feet (6-meters).
- “Looped” or “inverted” clocking may be required for line speeds faster than 512 Kbps.

Note: The following protocols have limits as noted and are always considered low-speed lines:

- Bisync limited to a maximum of 64 Kbps
- Async limited to a maximum of 115.2 Kbps
- Async/PPP limited to a maximum of 230.4 Kbps

When Async-PPP is used at speeds above 115.2 Kbps, a high-speed cable must be used.

2. When using X.25 protocol, a maximum of 64 virtual circuits are allowed per IOA. Use the “Configuration validation procedure for System i5 IOPs” on page 11 to determine that enough memory and performance capacity is available on the IOP to support a higher number of virtual circuits.
3. Frame Relay and X.25 are not allowed on the same IOA, unless the information in “Configuration validation procedure for System i5 IOPs” on page 11 indicates that enough memory and performance capacity is available on the IOP to support both protocols on the IOP.
4. Frame Relay protocol has the following restrictions:
 - An EIA-232/V.24 connection is not supported.
 - The line speed must be 56 Kbps or greater.
 - One line of Frame Relay is allowed per IOA. Refer to “Configuration validation procedure for System i5 IOPs” on page 11 to determine if enough memory and performance capacity are available on the IOP to support more frame relay lines on both ports.
5. An IPX maximum of 1400 routes and 1400 services is allowed per line. IPX is only supported at OS/400 V5R1 and earlier and is not supported with OS/400 V5R2.

Note: If no IPX, the hard rules cover all requirements.

6. The “emulated LAN” support for ATM adapters has the following restrictions:
 - A maximum of two emulated LANs are supported per IOA.
 - When running two emulated LANs, the LANs must be of a different type, such as one token-ring and one Ethernet.
7. Provide the best performance. We recommend that these IOAs have a dedicated IOP, regardless of protocol.
8. The V.90 port of the #9771 supports Async, Async-PPP protocol, and Fax. Fax is supported at speeds up to 14.4 Kbps.
9. Workstations attached to the #4746 PCI Twinaxial IOA are limited to a maximum of 40 unique device addresses per IOA. The number of active workstation sessions is limited to 120 per IOA.
10. IPX is not supported on the #2817, #4815, #4816, and #4818 ATM IOAs or the #2743 1 Gbps PCI Ethernet IOA/#2760 PCI 1 Gbps Ethernet UTP Adapter or any adapter after OS/400 V5R2.
11. Use the hard rules values from “Hard rules: System i5, eServer i5, and iSeries IOA capabilities” on page 14.
12. When using the SDLC protocol, a maximum of 64 controllers per line is allowed, unless the conditions in the “Configuration validation procedure for System i5 IOPs” on page 11 indicate that enough memory and performance capacity are available on this IOP to support more controllers.
13. For best performance, spread high-speed IOAs, such as #2743, #2760, #2765, #2766, #2787, #5700, #5701, #5704, #5760, and #5761 controllers across the system I/O buses, first by HSL loop, then by I/O tower, and then by Multi-Adapter Bridge.

IOP rules: iSeries Integrated Server

Note: Throughout this section, *Integrated xSeries Server system units and expansion towers* refers to these systems and PCI towers: Models 800, 810, 825, 870 and 890, and #5075, #5078, #0578, #5074/#0574, #5088, #0588, #5094/#0694, #5095, #0595, #5294, #8079, #8093, #8094, #8294, 9194 and #9094.

PCI Integrated Netfinity Server and PCI Integrated xSeries Server features #2790/#2890, #2791/#2891, #2792/#2892, #2799/#2899, and #4710/#4810 are considered special circumstance IOPs in that they include an IOP and IOA. Storage and performance capacity calculations are not used with these Integrated Servers. The #4811, #4812, #4813, #9812, and #9813 are the latest Integrated xSeries Server IOAs, new with i5/OS V5R3. They do require an IOP.

There is a maximum of three Integrated xSeries Servers per #5088, #5094 top, and #5294 bottom tower.

The #2790/#2890 PCI Integrated Netfinity Server and the #2791/#2891 or #2799/#2899 PCI Integrated xSeries Server support (drive) the following IOAs only:

- ▶ #2743 1 Gbps PCI Ethernet IOA
- ▶ #2744 PCI 100 Mbps Token Ring IOA
- ▶ #2760 PCI 1 Gbps Ethernet UTP Adapter
- ▶ #4838 PCI 100/10 Mbps Ethernet IOA

The #4710/#4810 and #2792/#2892 PCI Integrated xSeries Servers support the following LAN IOAs in addition to its embedded 10/100 Mbps Ethernet controller:

- ▶ #2744 PCI 100 Mbps Token Ring IOA
- ▶ #5700 PCI 1 Gbps Ethernet IOA
- ▶ #5701 PCI 1 Gbps Ethernet UTP IOA

The #2890, #2891, #2892, #2899, and #4810 are customer-installable features. These adapters are supported in the Models 800 and 810 system units, and in any Integrated xSeries Server I/O expansion tower attached to those system units. All #2790, #2791, #2792, #2799, and #4710 are converted to #2890, #2890, #2892, #2799, and #4810 when installed in a 520, 550, 570, or 595 system. See the note below.

Note: An Integrated xSeries Server is not customer installable in a #5074/#0574, #5079, #5094/#0694, #8294/#9194 or #5294 Expansion Tower. In the case of an Integrated xSeries Server in a #5074/#0574, #5079, #5094/#0694, or #5294 Expansion Tower attached to a Model 810 system unit, the Integrated xSeries Server feature code indicates customer installable. However, the feature can only be installed by qualified service personnel.

The #2790, #2791, #2792, #2799, and #4710 are *not* customer-installable features. These adapters are supported in the Models 825, 870, and 890 system units, and in any Integrated xSeries Server I/O expansion towers attached to those system units.

In a #0588/#5088 Expansion Tower, the #2792/#2892 and #4710/#4810 are the only Integrated xSeries Server features allowed in slot C01.

In Integrated xSeries Server system units and expansion towers, except for the 800 and 810 system units, the #2790, #2791, #2799, #2890, #2891, and #2899 occupies two full backplane slots. The third backplane slot is reduced to a “short” slot, which supports a “short” IOA only.

In the Models 800 and 810 system units, the #2890, #2891, or #2899 occupies one full backplane slot. The second backplane slot is reduced to a “short slot” that supports a “short” IOA only.

In Integrated xSeries Server system units and expansion towers, except for the 800 and 810 system units, the #2792/#2892, #4710/#4810, #4811, #4812, #4813, #9812, and #9813 PCI Integrated xSeries Servers occupy two full backplane slots and do not reduce a third backplane slot to a “short” slot.

In the Model 800 and 810 system units, the #2892 and #4810 PCI Integrated xSeries Servers occupy one full backplane slot and do not reduce a second backplane slot to a “short” slot.

If a #2790/#2890, #2791/#2891, #2792/#2892, #2799/#2899, or #4710/#4810 Integrated xSeries Server is installed in slot C01 of a #5095/#0595, the #9844 Base PCI IOP (or any other IOP in slot C01) must be moved from slot C01 and repositioned. Reposition the associated IOAs from slots C02, C03, and C04.

Model 520 PCI configuration validation examples

Follow the example in this section to understand better the configuration validation procedure and the use of hard and soft rules for PCI configurations.

Example: Model 520 with 1.6 GHz Processor

The customer requests a Model 520 with the following capabilities:

- ▶ RAID-5 disk protection (support for 4 drives in the base)
- ▶ Electronic Customer Support (ECS)
- ▶ Attachment to a 100 Mbps Ethernet
- ▶ Twinaxial console

To provide these capabilities, the following features are required:

- ▶ #2844 PCI IOP
- ▶ #2849 10/100 Mbps Ethernet Adapter (provides attachment to 100 Mbps Ethernet)
- ▶ #4746 PCI Twinaxial IOA (provides twinaxial console)
- ▶ #5709 RAID Enabler Card (provides RAID-5 disk protection)
- ▶ #9793 Base PCI 2-Line WAN w/Modem (provides ECS attachment)

After the customer identifies the IOPs and IOAs, validate the configuration by following the procedure in “Generating a valid configuration” on page 11.

The slot C IOP is examined first. The following process occurs:

1. Identify the IOP being considered.
2. Determine the capacity values for the selected IOP using the IOP capacity table. (See Table 2 on page 12.) Enter the memory and performance capacity values from the IOP capacity table (Table 2) onto line 6 of the Configuration Validation Form. (See Table 1 on page 12.)
3. The IOP has a memory value of 211 and a capacity value of 100. Enter those values on line 6 of Table 1.
4. Identify the IOAs to be controlled by the selected IOP.

There is a soft rule that specifies placing the #2849 10/100 Mbps Ethernet Adapter on a separate IOP for optimum performance. Therefore, the #4746 and #9793 are controlled by the first IOP.

5. Determine the capacity requirements of the selected IOAs using the hard rules for IOAs capabilities. (See Table 3 on page 14). Enter the storage and performance values from the IOP capacity table (Table 2) into lines 1 through 4 of the Configuration Validation Form (Table 1). Enter one IOA per line and remember that an IOP supports a maximum of four IOAs. The embedded SCSI and RAID enabler card count as single card. Use the RAID enabler IOP values instead of the SCSI values when RAID enabler card is installed.

The appropriate values are shown on lines 1 through 4 of the configuration example (Table 6). The slots that the cards occupy are also entered.

6. Review the soft rule requirements for System i5 IOAs. (See “Soft rules: System i5, eServer i5, and iSeries IOA requirements” on page 23.) If any of the restrictions described apply to the selected IOAs, use the values from Table 5 on page 23 to replace the values in the Configuration Validation Form. (See “Configuration validation form” on page 12.) When determining the values to use, be sure to account for both lines if you select the #9793 Two-Line WAN IOA with Modem.

Since ECS is the only protocol used on the #9793, none of the soft rules apply. There is no need to account for the second line on the #9793 since it is not used.

7. Add the IOA values in each column of Table 1. Place the totals on line 5.
8. Compare the totals on line 5 with the IOP Capability values on line 6.

Table 6 illustrates this scenario. All the numbers on line 5 are less than or equal to the corresponding values on line 6. Therefore, the configuration is valid.

Table 6 Model 520 configuration example

Line #	Item	Memory	Performance
1	IOA #1 SCSI RAID Enabler (C8)	29	21
2	IOA #2 #9793 Two-Line WAN IOA with Modem (slot C3)	15	14
3	IOA #3 #4746 PCI Twinaxial IOA (slot C06)	10	6
4	IOA #4 #4745 PCI 2-line WAN IOA (slot C05)	15	7
5	Total	69	48
6	IOP capability #2844 IOP	211	100

A second IOP configuration procedure:

Follow these steps to check the #2844 PCI IOP and its associated IOAs:

1. Identify the IOP to consider. The #2844 PCI IOP is to be used.
2. Use the IOP capacity table to determine the capacity values for the selected IOP. See Table 2 on page 12. Enter the values on line 6 of the Configuration Validation Form.
The #2844 PCI IOP has a memory value of 100 and a capacity value of 100. Enter those values on line 6.
3. Identify the IOAs to be controlled by the selected IOP. The #2849 10/100 Mbps Ethernet Adapter is to be controlled by the #2844 PCI IOP.
4. Use the hard rules for IOAs to determine the capacity requirements of the selected IOAs. See Table 3 on page 14. Enter the values onto lines 1 through 4 of the form (one IOA per line). Remember that an IOP supports a maximum of four IOAs.
The appropriate values are entered on lines 1 through 4. See Table 7 on page 30. The slots that the cards occupy are also entered.
5. Review the soft rules for IOAs. See Table 5 on page 23. If any of the restrictions described apply to the selected IOAs, use the values from the table to replace the values in the Configuration Validation Form.
There are no soft rules that apply other than placing the #2849 10/100 Mbps Ethernet Adapter on a separate IOP for optimum performance. This rule has been met.
6. Add the IOA values in each column. Place the totals on line 5.
7. Compare the totals on line 5 with those in Table 2 IOP Capacity on line 6.

Table 7 illustrates this scenario. All the numbers on line 5 are less than or equal to the corresponding values on line 6. Therefore, the configuration is valid.

Table 7 #2844 configuration example

Line #	Item	Memory	Performance
1	IOA #1 #2849 10/100 Mbps Ethernet Adapter (slot C2)	25	36
2	IOA #2		
3	IOA #3		
4	IOA #4		
5	Total	25	37
6	IOP Capability #2842 PCI IOP (slot C1)	100	100

This configuration leaves slot C02 empty. Based on the soft rules, slot C02 is not used unless something less than optimum performance is acceptable for the #4838 PCI 100/10 Mbps Ethernet IOA.

Notices

This information was developed for products and services offered in the U.S.A.

IBM may not offer the products, services, or features discussed in this document in other countries. Consult your local IBM representative for information on the products and services currently available in your area. Any reference to an IBM product, program, or service is not intended to state or imply that only that IBM product, program, or service may be used. Any functionally equivalent product, program, or service that does not infringe any IBM intellectual property right may be used instead. However, it is the user's responsibility to evaluate and verify the operation of any non-IBM product, program, or service.

IBM may have patents or pending patent applications covering subject matter described in this document. The furnishing of this document does not give you any license to these patents. You can send license inquiries, in writing, to:

IBM Director of Licensing, IBM Corporation, North Castle Drive Armonk, NY 10504-1785 U.S.A.

The following paragraph does not apply to the United Kingdom or any other country where such provisions are inconsistent with local law: INTERNATIONAL BUSINESS MACHINES CORPORATION PROVIDES THIS PUBLICATION "AS IS" WITHOUT WARRANTY OF ANY KIND, EITHER EXPRESS OR IMPLIED, INCLUDING, BUT NOT LIMITED TO, THE IMPLIED WARRANTIES OF NON-INFRINGEMENT, MERCHANTABILITY OR FITNESS FOR A PARTICULAR PURPOSE. Some states do not allow disclaimer of express or implied warranties in certain transactions, therefore, this statement may not apply to you.

This information could include technical inaccuracies or typographical errors. Changes are periodically made to the information herein; these changes will be incorporated in new editions of the publication. IBM may make improvements and/or changes in the product(s) and/or the program(s) described in this publication at any time without notice.

Any references in this information to non-IBM Web sites are provided for convenience only and do not in any manner serve as an endorsement of those Web sites. The materials at those Web sites are not part of the materials for this IBM product and use of those Web sites is at your own risk.

IBM may use or distribute any of the information you supply in any way it believes appropriate without incurring any obligation to you.

Information concerning non-IBM products was obtained from the suppliers of those products, their published announcements or other publicly available sources. IBM has not tested those products and cannot confirm the accuracy of performance, compatibility or any other claims related to non-IBM products. Questions on the capabilities of non-IBM products should be addressed to the suppliers of those products.

This information contains examples of data and reports used in daily business operations. To illustrate them as completely as possible, the examples include the names of individuals, companies, brands, and products. All of these names are fictitious and any similarity to the names and addresses used by an actual business enterprise is entirely coincidental.

COPYRIGHT LICENSE:

This information contains sample application programs in source language, which illustrates programming techniques on various operating platforms. You may copy, modify, and distribute these sample programs in any form without payment to IBM, for the purposes of developing, using, marketing or distributing application programs conforming to the application programming interface for the operating platform for which the sample programs are written. These examples have not been thoroughly tested under all conditions. IBM, therefore, cannot guarantee or imply reliability, serviceability, or function of these programs. You may copy, modify, and distribute these sample programs in any form without payment to IBM for the purposes of developing, using, marketing, or distributing application programs conforming to IBM's application programming interfaces.

This document created or updated on February 22, 2006.



Send us your comments in one of the following ways:

- ▶ Use the online **Contact us** review redbook form found at:
ibm.com/redbooks
- ▶ Send your comments in an email to:
redbook@us.ibm.com
- ▶ Mail your comments to:
IBM Corporation, International Technical Support Organization
Dept. HYJ Mail Station P099
2455 South Road
Poughkeepsie, NY 12601-5400 U.S.A.

Trademarks

The following terms are trademarks of the International Business Machines Corporation in the United States, other countries, or both:

Redbooks (logo)  ™	xSeries®	OS/400®
Eserver®	AS/400e™	POWER™
eServer™	AS/400®	POWER5+™
iSeries™	IBM®	Redbooks™
i5/OS®	Netfinity®	

The following terms are trademarks of other companies:

IPX, Ultra, and all Java-based trademarks are trademarks of Sun Microsystems, Inc. in the United States, other countries, or both.

Linux is a trademark of Linus Torvalds in the United States, other countries, or both.

Other company, product, and service names may be trademarks or service marks of others.